

The VM2J-iB is a solid-state, Class AB broadband power amplifier module based on advanced GaN HEMT technology. The VM2J-iB is intended for CW applications, offering exceptional performance in a small and lightweight form factor. Advanced and unique features are accessible via an FPGA-based serial interface. The module primary functions may also be controlled using the discrete I/O interface.

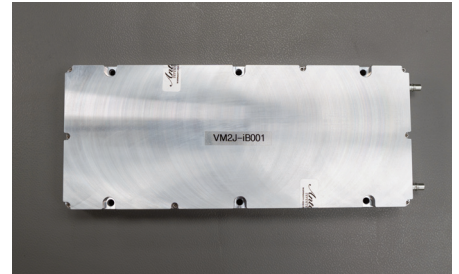
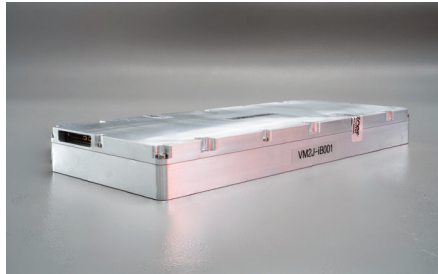
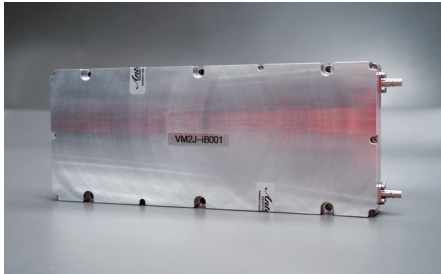

PRODUCT FEATURES

- Small Form Factor (230 x 95 x 25 mm): Smaller and Lighter than Competing Models
- Exceptional Bandwidth, Output Power and Efficiency
- Ultra-Fast and Effective Mute Function
- Comprehensive Built-In Test, Telemetry and Protection
- High-Resolution Power / Gain Control
- Supports Internally-Stored Calibration Look-Up Tables
- Innovative Space-Saving Connector System

TYPICAL APPLICATIONS

The VM2J-iB is ideal for:

- Electronic Warfare / Countermeasures
- Broadband Mobile Jamming Applications
- Airborne, Aircraft and UAV Equipment
- Power Amplifier Stage for Wireless Infrastructure
- Test and Measurement Equipment
- General Purpose Broadband Transmitter Amplification

ELECTRICAL CHARACTERISTICS TC = +25 °C, 32 VDC, 50 Ω System (unless otherwise noted)

PARAMETER	MIN	TYP	MAX	UNITS
Operating Frequency Range	400		2900	MHz
Saturated Output Power (Psat)	50	50.5		dBm
Power-Added Efficiency @Psat	30	37		%
Gain @Psat		50		dB
Gain Flatness @P 100w		±5		dB
Input Return Loss	10			dB
Output Return Loss		10		dB
Input Power @Psat		0	10	dBm
Noise Figure			15	dB
Harmonic Emissions			-10	dBc
Non-Harmonic Spurious Emissions			-60	dBc
DC Supply Voltage	24	28	32	V
Current Consumption @P 100w		9.5	11.5	A
Mute/ Enable Mode Switching Characteristics:				
tENABLE, tMUTE (50% CTRL to 10/90% RF)		500	1000	ns
Isolation in Mute Mode	80			dB
Current Consumption in Mute Mode			100	mA
Current Consumption in Shutdown			10	mA
Gain Control Characteristics:				
Adjustment Range		31.5		dB
Adjustment Resolution		0.5		dB

CONTROL CHARACTERISTICS AND ADVANCED FEATURES

PARAMETER	VALUE
Ultra-Fast Mute/Enable Switching	Control via discrete input Additional control via serial comms interface
Serial Communications Interface (High Noise Immunity)	2-wire serial interface required to access advanced features Interface: RS-485 Half Duplex Data Rate: 1 Mbps
High-Resolution Power/Gain Control	Control via serial comms interface
User Memory	16 MB (128 Mbit) serial flash memory Supports multiple calibration tables or user-specific data Control via serial comms interface
Built-In Test Functions	Power-on BIT (PBIT) Continuous BIT (CBIT) Initiated BIT (IBIT) All BIT data is accessible via the serial comms interface
Temperature BIT	Baseplate and Core temperatures monitored Range: -40 °C to +125 °C Accuracy: ±3 °C
Voltage BIT	All critical voltage rails monitored Accuracy: ±5 %
Current BIT	Critical device currents and total input current monitored Accuracy: ±5 %
Memory Integrity BIT	CRC checking of User Settings and Factory Settings
Alarm Output	Discrete output Logical OR status of individual BIT flags Behaviour may be modified or disabled via serial comms interface
Elapsed On-Time Recorder	34 years of total (power-on) time accumulation 17-Bit power-up event counter
Electronic Identification Data (Non-Volatile)	Part number Serial number Revision
Thermal Overload Protection	Set Threshold: +90 °C Clear Threshold: +82 °C
Additional Features	DC supply reverse polarity protection Control interface ESD protection Shutdown function Integrated FWD and REV Power Monitors
Optional Features	Other serial interface standards e.g. I2C, SPI, CAN Integrated T/R Switch (adds 20 mm to length)

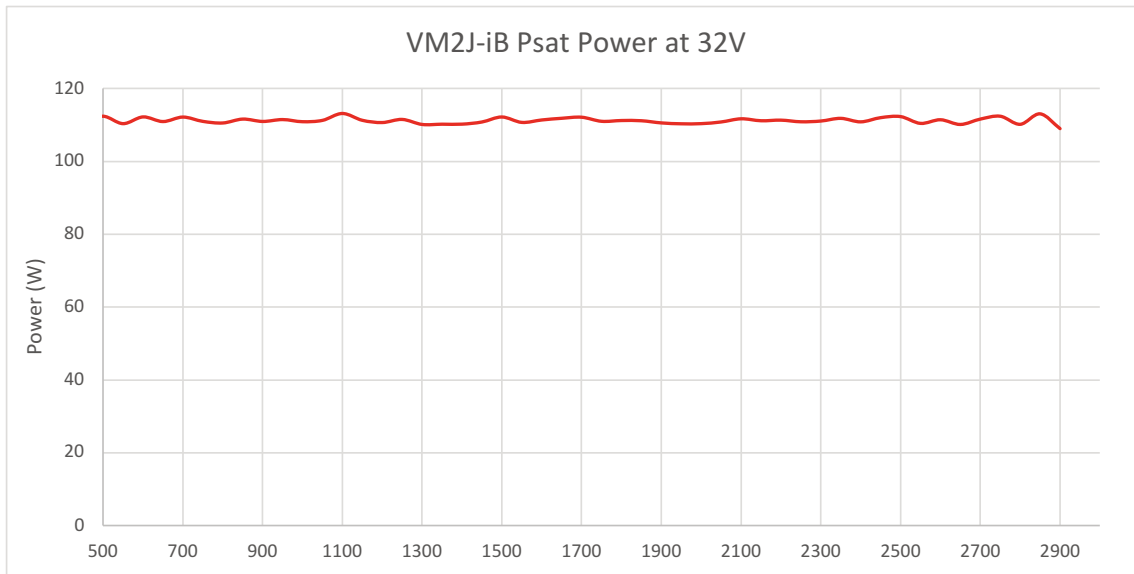

MECHANICAL CHARACTERISTICS

PARAMETER	VALUE	UNITS
Dimensions (excl. connectors)	230 x 95 x 25	mm
Mass	900	g
RF In / Out Connectors	SMA Female	-
DC In / Control Connector	Mixed Technology Male: 2 Power + 12 Signal	-
Cooling Method	External Heatsink to Baseplate (Not Supplied)	-

ENVIRONMENTAL CHARACTERISTICS

PARAMETER	MIN	TYP	MAX	UNITS
Case or Baseplate Temperature	-20		+80	°C
Cold Start Temperature (performance not guaranteed)	-40			°C
Relative Humidity (non-condensing)			95	%
Ingress Protection		IP51		-

ABSOLUTE MAXIMUM RATINGS (Not simultaneous)

RF Input Power	+10 dBm
RF Output Mismatch	VSWR ∞:1 at all phase angles (for 1 minute)
Case or Baseplate Temperature (Operating)	-20 °C to +85 °C
Case or Baseplate Temperature (Non-Operating)	-40 °C to +100 °C
DC Supply Voltage (DC IN+ to GND)	24 V to 32 V
Control Interface (I/O to GND)	-0.5 V to 5.5 V
Mute / Enable Mode Switching Frequency	50 kHz
ESD Sensitivity	HBM Class 1A

Exceeding maximum ratings may cause permanent damage. Operation between operating range maximum and absolute maximum for extended periods may reduce device reliability. Absolute maximum ratings are stress figures only and functional operation under these conditions is not implied.

CONNECTOR PINOUT

Pin	Signal	Description	Electrical Characteristics	Direction
A	DC_IN-	VDC return	0 V	-
B	DC_IN+	VDC supply voltage	24-32 V @14 A max. ≤100 mV pk-pk ripple in 20 MHz BW	-
1	COMMS_RS485HD_P	RS485 non-inverting receiver input and non-inverting driver output	Refer to ADM3486E datasheet. Multidrop bus not supported. Keeper resistors required	In/Out
2	COMMS_RS485HD_N	RS485 inverting receiver input and inverting driver output	Refer to ADM3486E datasheet. Multidrop bus not supported. Keeper resistors required	In/Out
3	PA_GOOD	PA Good bit: '0' = Fault '1' = No Fault	3V3 CMOS	Out
4	GND	Signal return	0 V	-
5	CAN_TERM	Open end of 120 Ω resistor; other end internally connected to COMMS_CAN_P	125 mW rated	-
6	PA_SHDN	PA Shutdown bit: '0' = No Shutdown '1' = Shutdown	3V3 CMOS (5 V tolerant)	In
7	GND	Signal return	0 V	-
8	TX_EN	Transmit Enable bit: '0' = Mute '1' = Transmit	3V3 CMOS (5 V tolerant)	In
9	COMMS_CAN_P	CAN non-inverting receiver input and non-inverting driver output	Refer to SN65HVD230D datasheet	In/Out
10	COMMS_CAN_P	CAN non-inverting receiver input and non-inverting driver output	Refer to SN65HVD230D datasheet	In/Out
11	COMMS_CAN_N	CAN inverting receiver input and inverting driver output	Refer to SN65HVD230D datasheet	In/Out
12	COMMS_CAN_N	CAN inverting receiver input and inverting driver output	Refer to SN65HVD230D datasheet	In/Out

PIN DESIGNATIONS: (Overrides any other definition)

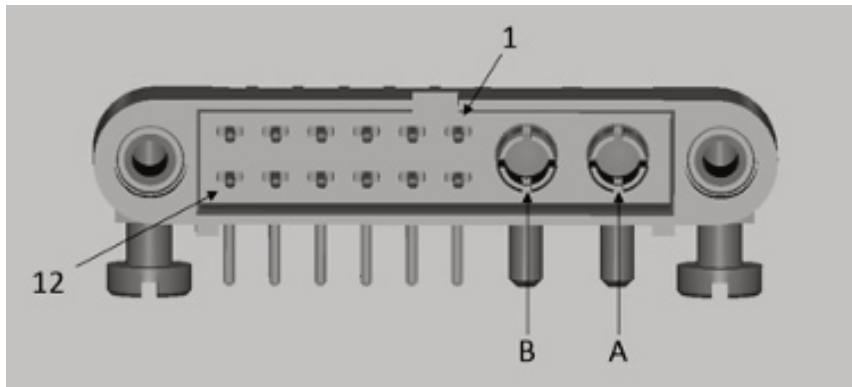

Connector Type:	CMM Micro Connector, 2x Male HP contacts + 12x Male LF contacts
Manufacturer:	Nicomatic (https://www.nicomatic.com/family/3)
Manufacturer Part No.:	221V12F23-0200-3400CMM
Mating Cycles:	≥500
Mates With:	222S12M16C-0200-4320 (Nicomatic) M80-4C11205F1-02-325-00-000 (Harwin)
Back Potting Shape:	14143-25 (Nicomatic)

OUTLINE DIMENSIONED DRAWING: (in millimetres)

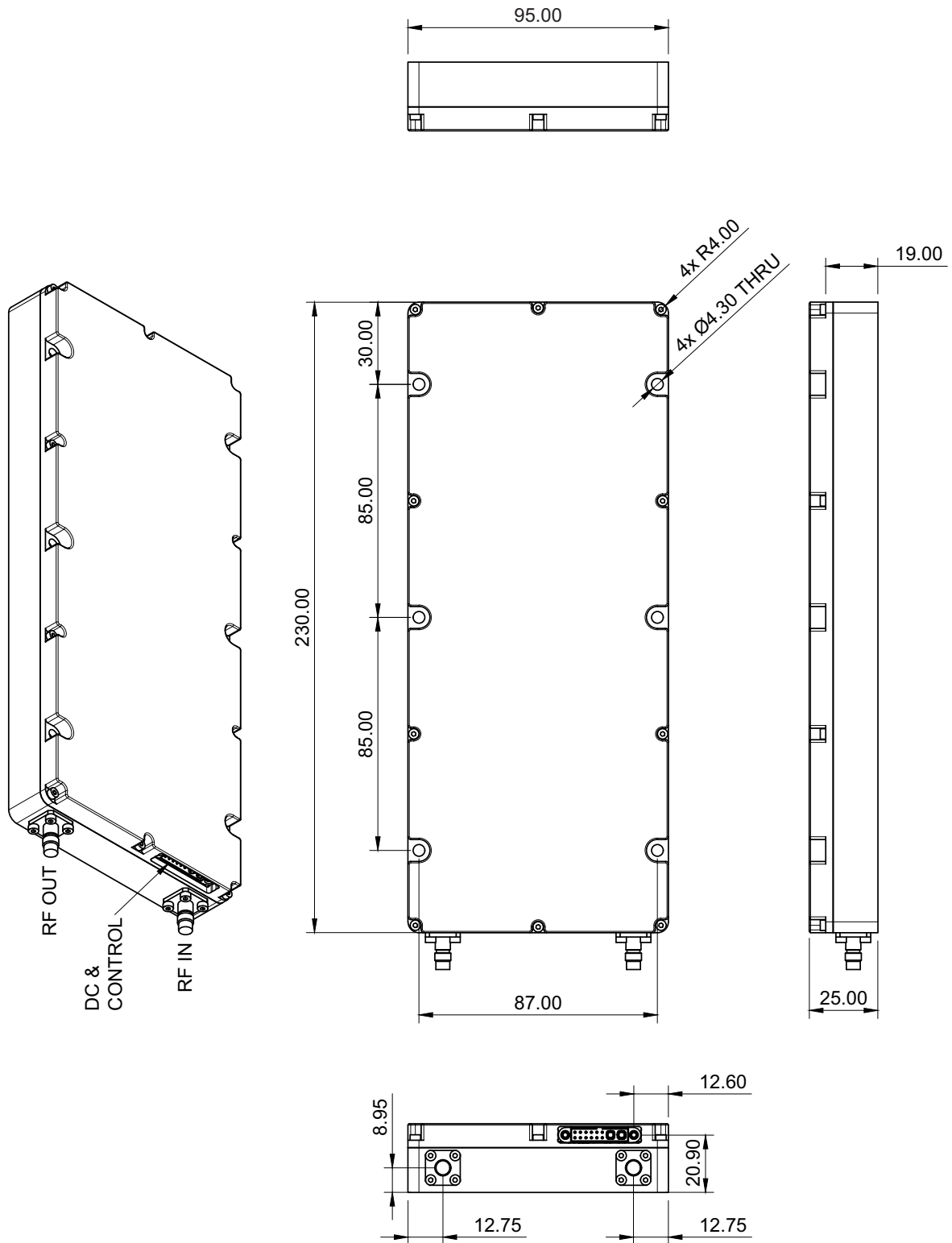

ESD PRECAUTIONS

Although this product contains circuitry to protect it from damage due to ESD, when handling this product observe the same precautions as with any other ESD-sensitive device.



RoHS COMPLIANCE

RoHS compliant parts and processes are used in the manufacture of this product.



QUALITY

This product is designed and manufactured in the United Kingdom in accordance with the ISO 9001:2008 Quality Management System.

ORDERING INFORMATION

MODEL NAME	PART NUMBER	FINISH
VM2J-iB	-	Iridite TM NCP